

VARITEx™

Ex eb IIC, Ex tb IIIC

COMPRESSION GLAND for Copper Tape Cable used for VSD



Features and Benefits

- For indoors, outdoors, Group II, III, Zone 1, 2, 21 and 22 hazardous areas.
- Two piece handling, no loose parts.
- Independent tightening of coil induces an inspectable positive contact on copper tape.
- Factory fitted captive elastomeric seal for Built-in Safety™.
- Seals on the outer sheath of the cable to IP66/68.
- Precision manufactured from high-quality brass (Marine Grade Electroless Nickel Plated™) available in stainless steel 316/316L on request.
- Complete with a thread sealing gasket and heavy duty locknut.



Technical Data

Type:	VARITEx™ (VRTX)
Gland Material:	Brass (Marine Grade Electroless Nickel Plated™), Stainless Steel 316/316L
Seal Material:	Standard Thermoset Elastomer or Extreme Temperature Seals
Seal Gasket Material:	HDPE, Nylon 66 or PTFE
Cable Type:	Copper Tape VSD (Variable Speed Drive)
Sealing Area:	Compression Seal on the Outer Sheath
Optional Accessories:	Adaptor, Reducer, Earth Tag, Locknut, Serrated Washer and Shroud
Note:	The installer should ensure that the materials are suitable for the installation environment.

Standards and Certifications

Equipment Protection Levels:	IECEX: Ex e IIC Gb, Ex tb IIIC Db ATEX: Ⓜ II 2GD, Ex eb IIC Gb, Ex tb IIIC Db TR CU: 1Ex e IIC Gb X / Ex tb IIIC Db X	
Continuous Operating Temp:	Standard Seals: -60°C to +95°C/100°C (HDPE/Nylon Sealing Gasket) Extreme Temp. Seals: -60°C to +160°C (PTFE Sealing Gasket)	
Conformance:	Standard:	Certificate:
IEC/BS EN	IEC/BS EN 62444	CML 14CA364
IECEX	IEC 60079 Parts 0, 1, 7, 15, 31	IEC Ex CML 18.0018X
ATEX	EN 60079 Parts 0, 1, 7, 31	CML 16ATEX1001X
INMETRO (Brazil)	ABNT NBR IEC 60079 Parts 0, 1, 7, 15, 31	TÜV 15.0483X
TR CU (Russia)	ГОСТ P M3K 60079-0, 7, 15, 31	TC RU C-ZA.ME92.B.00690
SANS	SANS 60079 Parts 0, 1, 7, 15, 31	MASC MS/13-028X
IP66/67/68 - Parallel	IEC 60529	
Corrosion Protection	ASTM B117-11, BS EN ISO 3231	EXOVA N968667
EMC Compatible	EN 55011:2009 + A1:2010, EN 55022:2010	SGS EMC197708/1

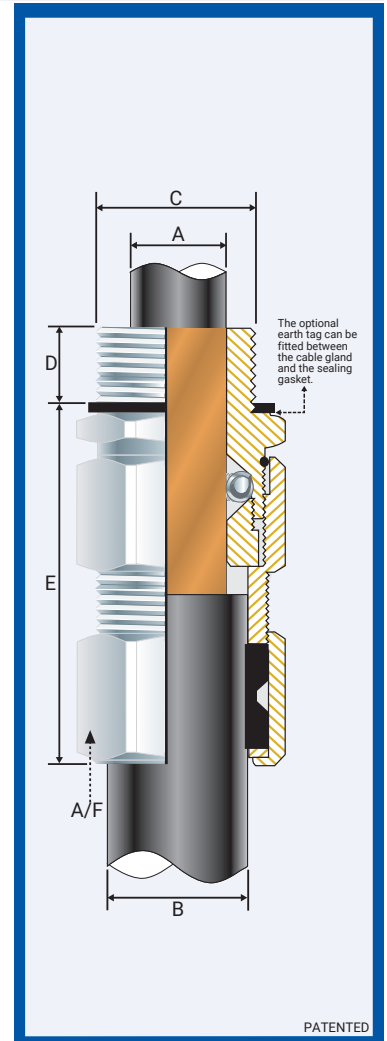

Conditions for Safe Use - X

- The cable glands shall only be used where the temperature, at the point of entry, is between -60°C and +95°C (standard seal & HDPE sealing gasket), +100°C (standard seal and Nylon sealing gasket) or +160°C (extreme temp. seal & PTFE sealing gasket) depending on seal and gasket used.
- The cable glands may only be used on fixed installations where the cable is clamped or stress applied to the cable in the gland is prevented.

Product Code	Cable Conductor Size	Gland Size Reference	Metric Entry Thread		Cable Detail				Maximum Length 'E'	Hexagonal Detail		Installation Torque Value Nm
			'C'	Min 'D'	Inner Over Tape		Outer			Max 'Flats'	Max 'Crns'	
					Min 'A'	Max 'A'	Min 'B'	Max 'B'				
0531-0S	2.5	0-20s	M20x1.5	15	9.6	11.5	13.0	20.0	61.0	30.0	34.0	23.1
0531-0	4.0	0-20	M20x1.5	15	10.8	12.5	13.0	20.0	61.0	30.0	34.0	23.1
053101	6.0	1-20	M20x1.5	15	12.2	14.0	13.0	20.0	61.0	30.0	34.0	23.1
053122	10.0	2s-25s	M25x1.5	15	13.8	16.0	18.0	26.0	64.0	38.0	43.0	33.0
053102	16.0	2-25	M25x1.5	15	16.0	20.0	18.0	26.0	65.0	38.0	43.0	33.0
053133	25.0	3s-32s	M32x1.5	15	20.0	23.0	23.0	28.0	68.0	45.0	51.0	46.2
053103	35.0	3-32	M32x1.5	15	22.0	23.5	23.0	28.0	68.0	45.0	51.0	46.2
053144	50.0	4s-40s	M40x1.5	17	23.5	28.0	28.0	39.5	75.0	55.0	62.0	57.2
053104	70.0	4-40	M40x1.5	17	28.0	32.0	28.0	39.5	74.0	55.0	62.0	57.2
053155	95.0	5s-50s	M50x1.5	17	32.0	36.0	35.2	42.0	81.0	65.0	73.0	62.7
053105	120.0	5-50	M50x1.5	17	35.5	39.0	40.0	46.0	85.0	65.0	73.0	62.7
053166	150.0	6s-63s	M63x1.5	17	39.0	45.0	45.5	54.0	85.0	80.0	90.0	72.6
053106	185.0	6-63	M63x1.5	17	44.0	49.5	45.5	54.0	85.0	80.0	90.0	72.6
053106L	240.0	6L-63L	M63x1.5	17	49.0	54.0	54.6	62.0	83.0	80.0	90.0	72.6
053107	300.0	7-75	M75x1.5	17	54.0	59.0	59.0	72.1	93.0	96.0	108.0	72.0
053108	300.0	8-80	M80x2	17	59.0	64.0	65.0	77.5	93.0	96.0	108.0	72.0

All dimensions are in mm. Intermediate thread sizes are available on request.

CCGG reserves the right to make alterations to the technical data, dimensions, designs and products available without notice. The illustrations cannot be considered binding. Please contact CCGG for assistance.

VRTX-EMC140920E

VARITEx™ COMPRESSION GLAND Ex eb IIC, Ex tb IIIC

ENCLOSURES AND EQUIPMENT TO WHICH CABLE GLANDS ARE FITTED:-

- Must be made from materials which are compatible with the cable gland materials.
- Have a sealing area around the cable gland entry point with a surface roughness <math>< Ra 6.3 \mu m</math>.
- Have entries that are perpendicular to the enclosure face in the area where the cable gland will seal to within 2.5°.
- Are sealed using the supplied sealing gasket (parallel threads) or by fully tightening into a threaded entry (tapered threads). Note that for tapered threads the IP rating can be improved to IP68 with the use of a suitable thread sealant.

MUST HAVE THREADED ENTRIES

- The same thread size as the cable gland. (Thread adapters should be used to correct

any mismatch).

- With a thread tolerance of metric class '6H' or equivalent.
- Where the thread length is a minimum of 10mm for Ex d applications or 3mm for all other applications

OR CLEARANCE HOLES (not Ex d)

- Where the hole size is the thread nominal size with a tolerance of +0.1 to +0.7mm. (e.g. the clearance hole for an M20 thread will have a diameter between 20.1mm and 20.7mm).
- Through material that is between 1mm and 12mm thick. (Thicker materials can be accommodated using glands with extended entry threads.)

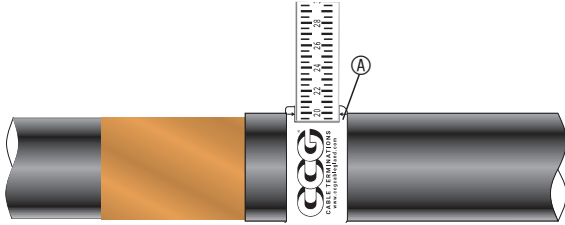

1. For accurate sizing, use a CCG Dimension Tape ① on the inner and outer cable sheath.

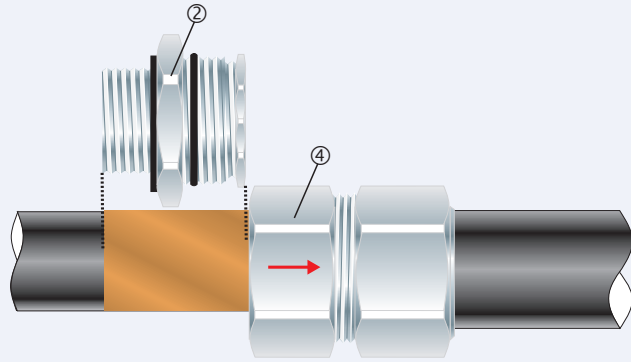

2. Screw the body ④ off and pass the cable end through the body ④. Cut the PVC sheath exposing the copper tape to the length of the inner ②.

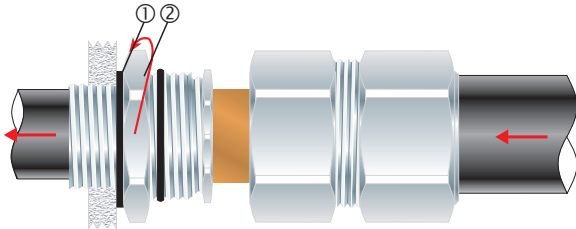

3. To maintain IP66/68 ensure gasket ① is in place. Screw the inner ② into the apparatus. Pass the cable through the inner ②.

Alternative installation through an unthreaded entry.

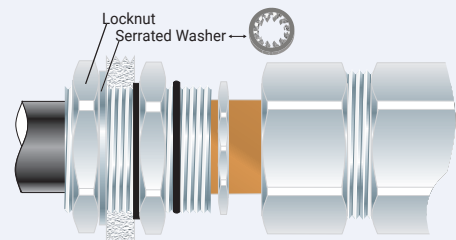

If the apparatus is untapped use a locknut.

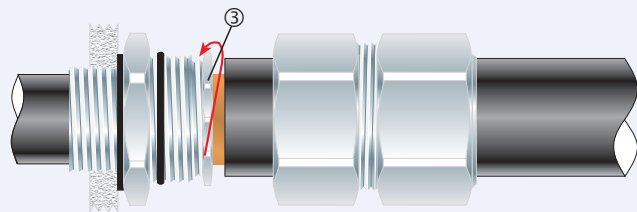

4. Tighten the compression nut ③ until the coil is in contact with the tape, then turn a half turn.

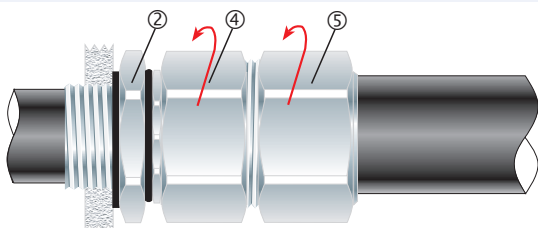

5. Tighten the body ④ onto the inner ②. Tighten the outer nut ⑤ to produce a moisture proof seal by turning till the seal makes contact with the outer sheath of the cable and then make one full turn.