

A2EX-FHC

Ex db IIC, Ex eb IIC, Ex tb IIIC, Ex nR IIC

COMPRESSION GLAND for Unarmoured Cable Housed In Conduit

Features and Benefits

- For indoors, outdoors, Group II, III, Zone 1, 2, 21 and 22 hazardous areas.
- For use with all types of unarmoured cable housed in rigid or flexible conduit.
- Harder outer seal grips the cable giving superior cable retention and IP rating.
- Fitted with a rotating female conduit coupler.
- Factory fitted with a specially formulated elastomeric seal for Built-in Safety™, seals on the inner sheath of the cable.
- Precision manufactured from high-quality brass (Marine Grade Electroless Nickel Plated™) available in stainless steel 316/316L on request.
- Complete with a thread sealing gasket and an end cap safety gauge for correct gland selection.



Technical Data

Type:	A2EX-FHC
Gland Material:	Brass (Marine Grade Electroless Nickel Plated™), Stainless Steel 316/316L
Seal Material:	Standard Thermoset Elastomer or Extreme Temperature Seals
Seal Gasket Material:	HDPE, Nylon 66 or PTFE
Cable Type:	Unarmoured Housed in Conduit
Sealing Area:	Inner Sheath
Optional Accessories:	Adaptor, Reducer, Earth Tag, Locknut, Serrated Washer and Shroud
Note:	The installer should ensure that the materials are suitable for the installation environment.

Standards and Certifications

Equipment Protection Levels:	IECEX: Ex db IIC Gb, Ex eb IIC Gb, Ex nR IIC Gc, Ex tb IIIC Db ATEX: Ⓜ II 2GD, II 3G, Ex db IIC Gb, Ex eb IIC Gb, Ex tb IIIC Db, Ex nR IIC Gc TR CU: 1Ex d IIC Gb X / 1Ex e IIC Gb X / 2Ex nR IIC Gc X / Ex tb IIIC Db X	
Continuous Operating Temp:	Standard Seals: -60°C to +95°C/100°C (HDPE/Nylon Sealing Gasket) Extreme Temp. Seals: -60°C to +160°C (PTFE)	
Conformance:	Standard:	Certificate:
IEC/BS EN	IEC/BS EN 62444	CML 14CA364
IECEX	IEC 60079 Parts 0, 1, 7, 15, 31	IEC Ex CML 18.0018X
ATEX	EN 60079 Parts 0, 1, 7, 31 EN 60079 Parts 0,15	CML 16ATEX1001X CML 16ATEX4002X
INMETRO (Brazil)	ABNT NBR IEC 60079 Parts 0, 1, 7, 15, 31	TÜV 15.0483X
TR CU (Russia)	ГОСТ Р МЭК 60079-0, 7, 15, 31 ГОСТ IEC 60079-1	TC RU C-ZA.ME92.B.00690
KCs (Korean)	Notification of Ministry of Labour No.2013-54	16-AV4BO-0266-9X
SANS	SANS 60079 Parts 0, 1, 7, 15, 31	MASC MS/13-028X
IP66/68 100m - Parallel	IEC 60529	CML 15Y728
IP65/66 - Tapered	IEC 60529	
Corrosion Protection	ASTM B117-11, BS EN ISO 3231	EXOVA N968667
Marine ABS	IEC 60079 Parts 0, 1, 7, 15, 31 and IEC 60529	ABS 20-SG1952706-PDA
DNV-GL	IEC 60079 Parts 0, 1, 7 and IEC 60529	DNV-GL TAE0000010
EMC Compatible	EN 55011:2009 + A1:2010, EN 55022:2010	SGS EMC197708/1



Conditions for Safe Use - X

- The cable glands shall only be used where the temperature, at the point of entry, is between -60°C and +95°C (standard seal & HDPE sealing gasket), +100°C (standard seal and Nylon sealing gasket) or +160°C (extreme temp. seal & PTFE sealing gasket) depending on seal and gasket used.
- The gland may only be used on fixed installations where the cable is clamped or stress applied to the cable is prevented.
- According to IEC 60079-14, 10.6.2: An Ex d gland will only maintain Ex d integrity when used with substantially round, compact and filled cable. If not a CCG QuickStop-Ex® barrier gland should be used.

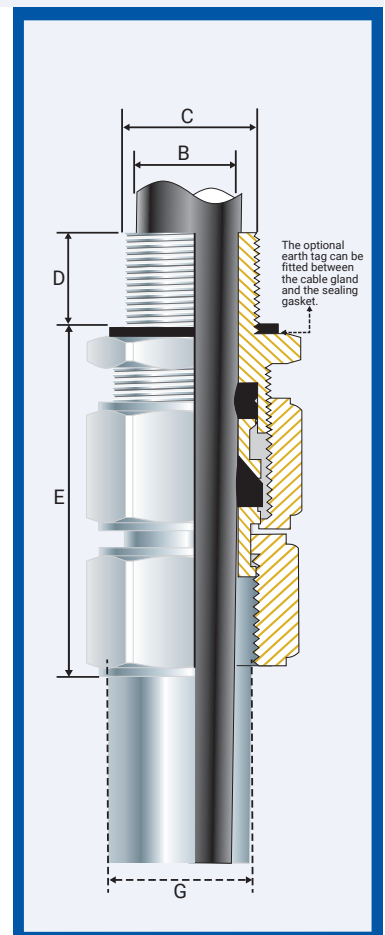

Product Code	Gland Size Reference	Metric Entry Thread		NPT Entry Thread		Cable Detail		Max Length 'E'	Female Conduit Thread		Hexagonal Detail		Install. Torque Value Nm
		'C'	Min 'D'	'C'	Min 'D'	Min 'B'	Max 'B'		Metric 'G'	NPT 'G'	Max 'Flats'	Max 'Crns'	
053700-16	00-16ss	M16x1.5	15			3.0	8.5	57.0	M16-M25	-	24.0	27.0	32.5
053700	00-20ss	M20x1.5	15	1/2/3/4	15.0	3.0	8.5	57.0	M16-M25	1/2/3/4	24.0	27.0	32.5
0537-0	0-20s	M20x1.5	15	1/2/3/4	15.0	7.0	12.0	57.0	M16-M25	1/2/3/4	24.0	27.0	32.5
053701	1-20	M20x1.5	15	1/2/3/4	15.0	11.0	15.0	64.0	M16-M25	1/2/3/4	27.0	30.0	32.5
053722	2s-25s	M25x1.5	15	3/4/1	15/19	11.5	17.5	71.0	M25	3/4/1	35.0	39.0	47.5
053702	2-25	M25x1.5	15	3/4/1	15/19	15.0	20.0	71.0	M25	3/4/1	35.0	39.0	47.5
053733	3s-32s	M32x1.5	15	1/1 1/4	19.0	16.0	22.0	85.0	M32	1/1 1/4	42.0	47.0	55.0
053703	3-32	M32x1.5	15	1/1 1/4	19.0	20.0	26.5	85.0	M32	1/1 1/4	42.0	47.0	55.0
053744	4s-40s	M40x1.5	15	1 1/4/1 1/2	19/21	22.0	31.5	102.0	M40	1 1/4/1 1/2	52.0	59.0	65.0
053704	4-40	M40x1.5	15	1 1/4/1 1/2	19/21	26.0	34.0	102.0	M40	1 1/4/1 1/2	52.0	59.0	65.0
053755	5s-50s	M50x1.5	15	1 1/2/2	21.0	29.0	38.0	112.0	M50	1 1/2/2	65.0	73.0	82.5
053705	5-50	M50x1.5	15	1 1/2/2	21.0	34.0	44.5	112.0	M50	1 1/2/2	65.0	73.0	82.5
053766	6s-63s	M63x1.5	15	2/2 1/2	21/30	38.0	50.0	144.0	M63	2/2 1/2	80.0	90.0	97.5
053706	6-63	M63x1.5	15	2/2 1/2	21/30	44.5	56.5	144.0	M63	2/2 1/2	80.0	90.0	97.5
053777	7s-75s	M75x1.5	15	2 1/2/3	30/32	50.0	62.0	164.0	M75	2 1/2/3	96.0	108.0	115.5
053707	7-75	M75x1.5	15	2 1/2/3	30/32	56.0	67.5	164.0	M75	2 1/2/3	96.0	108.0	115.5
053708	8-80	M80x2.0	20	3	32.0	59.0	69.0	175.0	M80	3	96.0	108.0	120.0
053799	9s-90s	M90x2.0	20	3/3 1/2	32/33	60.0	75.0	184.0	M90	3/3 1/2	111.0	125.0	120.0
053709	9-90	M90x2.0	20	3/3 1/2	32/33	73.0	81.5	184.0	M90	3/3 1/2	111.0	125.0	120.0
053710	10-100	M100x2.0	20	3/3 1/2/4	33/34	81.0	92.0	189.0	M100	3/3 1/2/4	125.0	141.0	120.0

All dimensions except NPT are in mm. Male Entry Thread 'C' and Female Entry Thread 'B' can only be any combination of either NPT or Metric threads. Intermediate thread sizes are available on request.

A2EX-FHC COMPRESSION GLAND Ex db IIC, Ex eb IIC, Ex tb IIIC, Ex nR IIC

ENCLOSURES AND EQUIPMENT TO WHICH CABLE GLANDS ARE FITTED:-

- Must be made from materials which are compatible with the cable gland materials.
- Have a sealing area around the cable gland entry point with a surface roughness <math>< Ra 6.3 \mu m.</math>
- Have entries that are perpendicular to the enclosure face in the area where the cable gland will seal to within 2.5°.
- Are sealed using the supplied sealing gasket (parallel threads) or by fully tightening into a threaded entry (tapered threads). Note that for tapered threads the IP rating can be improved to IP68 with the use of a suitable thread sealant.

MUST HAVE THREADED ENTRIES

- The same thread size as the cable gland. (Thread adapters should be used to correct

any mismatch).

- With a thread tolerance of metric class '6H' or equivalent.
- Where the thread length is a minimum of 10mm for Ex d applications or 3mm for all other applications

OR CLEARANCE HOLES (not Ex d)

- Where the hole size is the thread nominal size with a tolerance of +0.1 to +0.7mm. (e.g. the clearance hole for an M20 thread will have a diameter between 20.1mm and 20.7mm).
- Through material that is between 1mm and 12mm thick. (Thicker materials can be accommodated using glands with extended entry threads.)

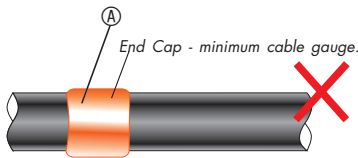

OR

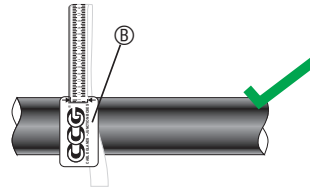

1. Check the correct gland size using an end cap (patented) (A). If the cable sheath passes through the hole in the end cap (A), use a gland one size smaller. For accurate sizing, use a CCG Dimension Tape (B) on the cable sheath.

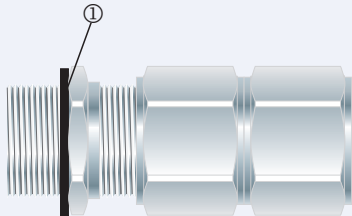

2. To maintain IP66/68 ensure the gasket (1) is in place.

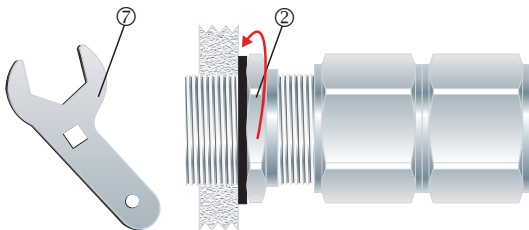

3. Screw the gland unit into the apparatus. Tighten the inner until hand tight (2) using a CCG Spanner (7) with 1/4 turn.

Alternative installation through an unthreaded entry.

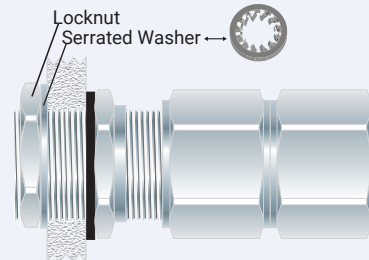

If the apparatus is untapped use a locknut.

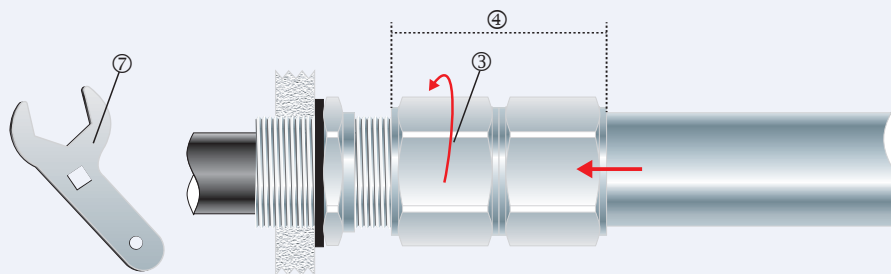

4. Pass the cable end through the conduit assembly (4) and the gland assembly. Tighten the outer (3) to the installation torque using a CCG Spanner (7) to produce a seal and grip on the cable.

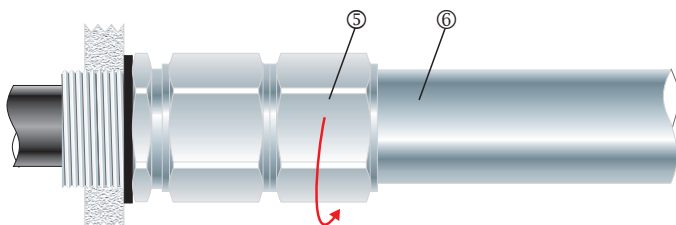

5. Fit the threaded conduit end (6) into the female rotating threads (5) as indicated.