

5-WAY HANDI FIT™

JUNCTION BOX - IP66/68

for General Industrial and Mining Electrical Installations



Features and Benefits

- 5-Way Handi Fit™ Box for general industrial and mining electrical installations.
- Screw-on lid provides ease of installation. Lid locking with a special key prevents unauthorized tampering.
- Supplied complete with safety securing lid lanyard.
- Only approved CCG cable glands and terminals must be used.
- No exposed metal parts.
- Dust and waterproof to IP66/68 when used with CCG sealed cable glands.
- No drilling or tapping of cable entries required.
- Mounting studs provided for DIN rail if using terminal blocks.
- Internal earthing to all entries and rail provided.
- One box offers 1, 2, 3, 4 or 5 way versatility (reduced stock holding).
- Box with see through polycarbonate "adapt-a-lids" available on request.

Technical Data

Type:	5-Way Handi Fit™ Box	
Box Material:	Impact corrosion and UV resistant glass reinforced polyester compound	
Seal Material:	Nitrile Rubber	
Inserts:	Brass, internal earth continuity ring and earth stud provided	
Optional Accessories:	Certified Terminals and Box Spanner (Lid Locking Key)	
	5-Blanking plugs are provided	

Standards and Certifications

Service Temperature:	-60°C to +110°C (Unfinished)	
Conformance:	Standard:	Certificate:
SANS/IEC	IEC 62208, IEC 62262	MASC 16-1787
IP66/68 2m Protection	IEC 60529	MASC 16-1787
Marine	IEC 60529	ABS 20-SG1952738-PDA
Deluge Protection DTS-01	DTS-01	CML 14CA370-1
Impact Protection IK10	IEC/BS EN 602208, 62262	CML 17Y11251
Short Circuit/Continuous Current	IEC 60947-7-2, IEC 62444	CATAPULT OR/15/11677_2
London Underground Approval	IEC 62208, IEC 62262	LU 3057

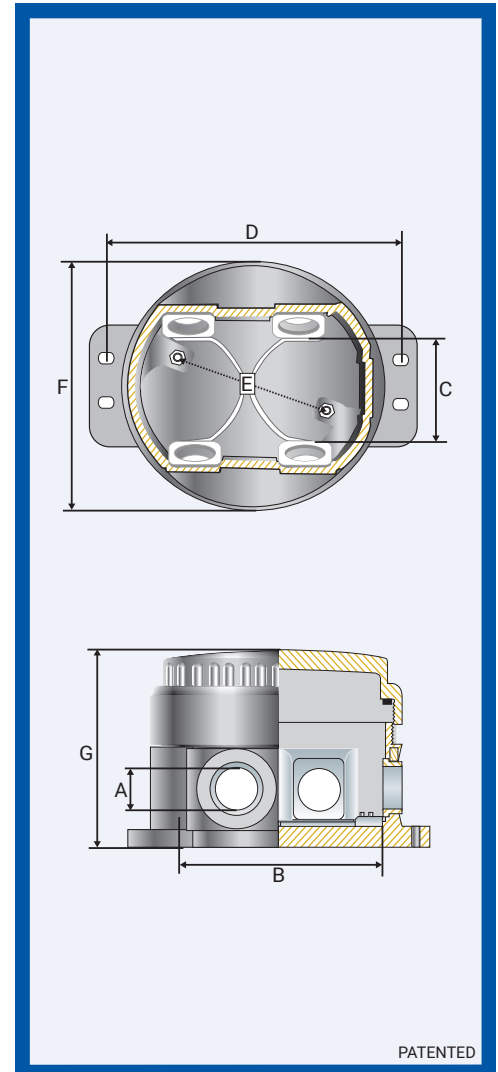

PATENTED



Guidelines for Correct Use

- The CCG lid locking key must be used to open and close units that do not have locking screws such as "clear cover units".
- When fitted with the clear lid, the unit must be installed to prevent UV exposure to the internal components fitted.
- Only the terminal blocks as per the description may be utilised in the junction box. Specific installation conditions as set by the terminal manufacturer/terminal certification must be considered. This includes considering the use of the applicable partitions and end plates for terminal blocks, conductor installation, tightening down of terminal block screws etc.
- Terminal blocks may only be utilized on the applicable rail and must allow sufficient space to make connections and to close the cover / lid.
- IP66/68 glands / plugs must be used in the threaded entries.
- Information with relation to entries is indicated in the instructions.

Product Code	Entry Thread 'A'	Internal Diameter 'B'	Distance Between Centres 'C'	Mounting Centres 'D'	Rail Mounting Centres 'E'	Overall Diameter 'F'	Outside Height 'G'
065002-H1	* M16	124.0	78.0	148.0	-	140.0	110.0
065002-H1	* M20	124.0	78.0	148.0	-	140.0	110.0
065002-H1	M25	124.0	78.0	148.0	-	140.0	110.0

All dimensions are in mm. * Different arrangement of entry sizes is available on request as stated above.

5-WAY HANDI FIT™ JUNCTION BOX

Wiring and Installation instructions for 5-Way Handi Fit™ Box with components

- Installation must be carried out by a competent person.
- Do not install under live current conditions.
- The box must not be modified in any way, as this will invalidate the certification.
- All wiring must be carried out in accordance with the relevant Codes of Practice.
- The wiring insulation must not extend by more than 1.0mm from the metal face of the terminal as shown in Figure 2.
- The voltage and current value of the box must not be exceeded, refer Table 2 See relevant certificate for current limitations for conditions of use / schedule of limitations.
- Only those terminals shown in the terminal schedule may be incorporated in the box, refer Table 1.
- Inner cable bedding must protrude into the box by a minimum of 20mm past the cable entry point.
- Not more than one single or multiple strand lead shall be connected into either side of the terminals.
- Only earth conductors of equal size shall be connected with rail mounted terminals.
- All terminal screws used and unused shall be tightened.
- A parallel shaft screw driver of the correct size should be used for rail mounted terminals screws.
- Where cables enter the box they must be secured by CCG Cable Glands appropriate to the make up of the cable.
- Unused entry apertures must be blanked with certified CCG Blanking Plugs.
- To maintain IP66/68 a thread seal gasket between the box and cable gland must be installed.
- Before replacing the lid, ensure the lid gasket is in place.
- The use of a CCG Box Spanner (Lid Locking Key) is required to maintain the tamper proof integrity of the box, refer Figure 1.

FIGURE 1

To ensure the box apparatus is tamper proof: Screw on, tighten and lock lid in place by means of a CCG Box Spanner (Lid Locking Key).

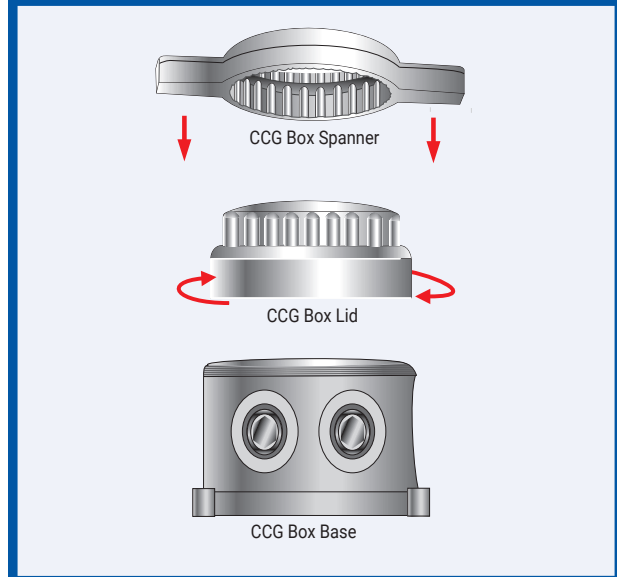

CCG Box Spanner

Product Code	Box Size
4012-0/1	0/1
401202	2

TABLE 1

Box Type	Box Size	Terminal Type and Size	Max Quantity	Rail Size
5-Way HandiFit™ Box	2	2.5mm ²	12	35
5-Way HandiFit™ Box	2	4mm ² mini terminal	10	15
5-Way HandiFit™ Box	2	4mm ²	10	35
5-WayHandiFit™ Box	2	6mm ²	8	35
5-WayHandiFit™ Box	2	10mm ²	7	35
5-Way HandiFit™ Box	2	16mm ²	6	35
5-Way HandiFit™ Box	2	35mm ²	3	35

TABLE 2

VOLTAGE PER TERMINAL CONFIGURATION

Terminals	Volt	Earth Terminals
AKZ 4	275V	AKE 4
WDU 2.5	550V	WPE 2.5
WDU 4	550V	WPE 4
WDU 6	550V	WPE 6
WDU 10	550V	WPE 10
WDU 16	550V	WPE 16
WDU 35	550V	WPE 35
WDU 70 N	550V	WPE 70 N



TS 15 Mini Rail

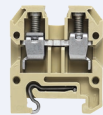

Mini Terminals for conductor sizes 0.5 to 4mm²



TS 35 Top Hat Rail

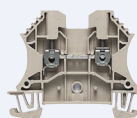

Terminals for conductor sizes 0.5 to 70mm²

FIGURE 2

The wiring insulation must not extend by more than 1.0mm from the metal face of the terminal as shown below.

