

# FLAMEPROOF - SPG

## JUNCTION BOX - Ex db I/IIC, Ex tb IIIC, IP66/68

### for Hazardous Installations

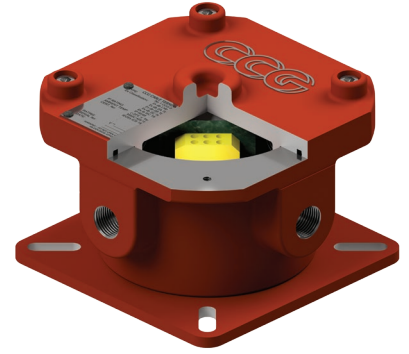

#### Features and Benefits

- For Group I Mining and Group II and III Surface.
- Robust construction.
- Dust and waterproof IP66/68.
- Any combination of 4-Way, 20 mm and 25 mm entries.
- Ex Terminals fitted on request.
- Superior corrosion resistant flamepaths.
- Captive high tensile stainless-steel fasteners.
- Integrated mounting back plate.
- Lid Spigot for ease of positioning.
- External earth stud.
- Different colour epoxy coatings available.



#### Technical Data

Type:	Flameproof - SPG Box
Box Material:	High quality cast iron and corrosion protection metallic finish
Recommended Gland:	Group I: FLP, FLP TR, FLP Hose, Armortex, Armortex VORTEX® or QuickStop-Ex® Barrier Glands Group II: E1EX, A2EX, Ex Corrosion Guards, Posi Grip, VORTEX® or QuickStop-Ex® Barrier Glands
Optional Accessories:	Ex Certified Terminals, End Connectors, Adaptors, Reducers and a Base Plate

#### Standards and Certifications

Equipment Protection Levels:	IECEX / SANS: Ex d I Mb / IIC GB T6, Ex tb IIIC T85°C Db ATEX/UKEX: Ex I M2 / II 2 G D, Ex d I Mb / IIC T6 Gb, Ex tb IIIC T85°C Db	
Ambient Temperature:	-20°C to +55°C	
Conformance:	Standard: Certificate:	
IECEX	IEC60079 Part 0, 1, 31, IEC 60529	IECEX MSC 15.0007X IECEX ICS 15.0005X
ATEX	EN 60079 Parts 0, 1, 31	CML15ATEX1065X
UKEX	BS EN 60079 Parts 0, 1, 31	CML 21UKEX1017X
SANS	SANS/IEC 60079 Part 0, 1, 31, SANS/IEC 60529	MASC MS/15-0212X
IP 66/68 Protection	IEC 60529	
Corrosion Protection	SANS 7253, EN 60068-2-52, ASTM B117-03 ISO 6988:7	19866 20109RE
Marine ABS	IEC/EN 60079 Parts 0, 1, 7, 31	ABS 20-1952738-1-PDA
DNV GL	IEC/EN 60079 Parts 0, 1, 7, 31, IEC 60529	DNV GL TAE0000011

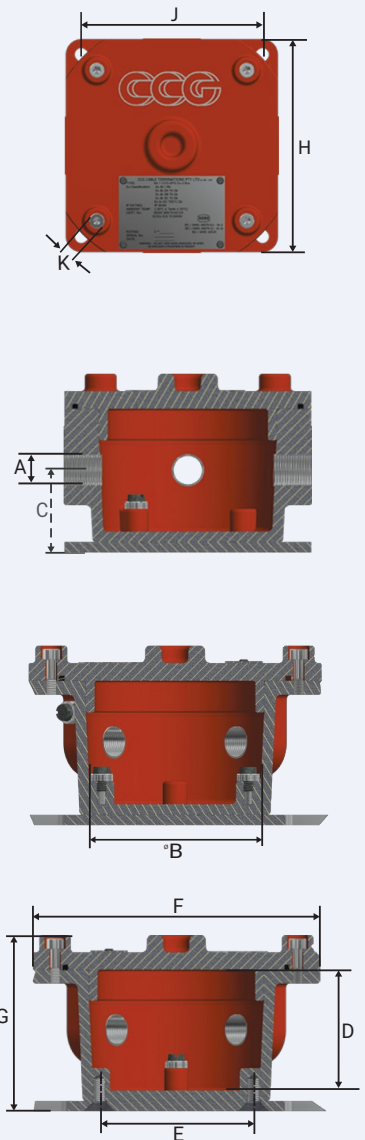

#### Conditions for Safe Use - X

- Suitably Ex db certified glands/adaptor/plugs shall be used to maintain the Flameproof (Ex d) / Dust protected (Ex tb), including IP rating characteristics as applicable.
- The nominal current (Max continuous circuit current) per circuit in the junction box is limited by the size of the conductor and the terminal block / connector ratings. The lower of the values in table 1 below and the maximum rated current of the terminal block / connector shall be used.

TABLE 1

Conductor Size	Current Limitation
1.5 mm <sup>2</sup>	15 A
2.5 mm <sup>2</sup>	17 A
4 mm <sup>2</sup>	20 A
6 mm <sup>2</sup>	25 A

TABLE 2

MARKING PLATE MARKING POSIBILITIES:- Ex db I Mb, Ex db IIC T6 Gb or ONE / MORE OF THE FOLLOWING MARKING	
Ex Classification Marking	Max. Flameproof Gap
Ex db I Mb	0.50
Ex db IIA T6 Gb	0.40
Ex db IIB T6 Gb	0.20
Ex db IIC T6 Gb	0.18

Product Code	Entry Thread 'A'	Internal Dimension 'B'	Dimension 'C'	Inside Height 'D'	Base Plate Screw Dim 'E'	Outer Diameter 'F'	Overall Height 'G'	Base Plate Dimension 'H'	Mounting Centres 'J'	Mounting Hole Dimension 'K'
100811-M20	M20	96.0	47.0	70.0	89.0	166.0	102.0	150.0	107.0	10.5
100811-M25	M25	96.0	47.0	70.0	89.0	166.0	102.0	150.0	107.0	10.5

All dimensions are in mm.

# FLAMEPROOF-SPG JUNCTION BOX

## Installation, Operation and Maintenance Instructions for Flameproof-SPG Box

All work to be done by an Ex competent person.

### Operation / Service of Flameproof-SPG Box

1. Test for gas in operations area.
2. Isolate the power at supply source and lock out.
3. Test with a multi meter to ensure that the circuit is isolated.
4. Ensure all bolts and glands are tight and secure.
5. Inspect flameproof gap on all flanges, this must not be exceeded, see Table 2.
6. Ensure that all earth wires are tight and up to standard.
7. **Do not open the box if a flammable gas mixture is present.**

### Maintenance of Flameproof-SPG Box

1. Isolate and lock out equipment for maintenance.
2. Test for gas before opening enclosure.
3. Unscrew bolts.
4. Missing bolts or screws should be replaced with the same type of bolt or screw. Length, type and grade (M6x0.8P x 20 long x grade A2-70).
5. Ensure all cable entries are tight.
6. Inspect all component mountings for tightness with the correct tools.
7. Clean flame-path and inspect flame-path for pit marks and rust. If pit marks are present and cannot be removed, contact the manufacturer.
8. Apply a film of non-hardening non-flammable grease (As per IEC 60079-1 clause 5.1).
9. Close enclosure lid and fasten all M6 bolts to 8.73 N.m maximum torque.
10. Test flame-path with an approved feeler gauge. Flame-path must not be exceeded, see Table 2
11. Remove lock and switch the electrical power back on.
12. Test the enclosure for the correct operation and fill in the maintenance report.

### Flameproof-SPG Box Instructions

1. Mounting.
    - 1.1. Do not mount to heat generating components where the heat generated can affect the temp class and electrical components.
  2. Gland Entries
    - 2.1. Only approved CCG Ex d glands for required gas group allowed.
    - 2.2. Flameproof glands and reducers allowed. (Only one reducer per entry).
    - 2.3. Unused gland entries to be plugged with "flameproof certified plugs".
    - 2.4. For all gland hole size and pitches see flameproof box drawing.
    - 2.5. All glands and blanking plugs must be torqued according to CCG's specifications.
  3. Bolted Covers
    - 3.1. Only CCG supplied M6 x 0.8P x 6H x 20 bolts must be used.
    - 3.2. No washers allowed on bolts.
    - 3.3. Bolts may not differ in length as to those supplied.
    - 3.4. All bolts must be torqued to a maximum torque values of Grade A2-70.

**NB – BOLTS FORM PART OF FLAME PROOF CERTIFICATION – INCORRECT THREAD PITCH OR BOLT LENGTH COULD LEAD TO AN EXPLOSION**
  4. Flameproof Box Flanges
    - 4.1. Flanges must be clean and free from dirt, rust or obstructions.
    - 4.2. Scratched or dented flanges will invalidate the flame-path.
  - 4.3. Flanges must be coated with a thin layer of non-hardening non-corrosive grease (refer to: IEC 60079-1 Clause 5.1).
  - 4.4. No other form of protective coating may be applied to the flanges.
- FLANGES FORM PART OF FLAME PATH**  
**NB – WHEN THE COVERS ARE BOLTED TO THE FLAMEPROOF BOX THE MAXIMUM GAP ALLOWED MUST NOT BE EXCEEDED, SEE TABLE 2.**
5. Modifications or Additions
    - 5.1. No modifications, mechanical or electrical are allowed.
    - 5.2. No welding of external or internal components allowed.
  6. Labelling
    - 6.1. The label may not be removed from the flameproof box.
  7. Mechanical Repair
    - 7.1. Mechanical repairs are only allowed to be performed in accordance to the certified drawings within tolerances approved by the testing authority.
    - 7.2. The original CCG label must at all times remain on the flameproof box, should it be repaired by other certified flameproof repairers.
  8. Electrical Repairs
    - 8.1. Electrical repairs may be performed provided that identical rated components are used.
    - 8.2. Electrical component maintenance and instructions refer, to component manufacturer.

TABLE 3

Box Type	Box Size	Terminal Type and Size	Max Quantity	Rail Size
Ex d Box	1	4mm <sup>2</sup> mini terminal	8	15
Ex d Box	2	4mm <sup>2</sup> mini terminal	8	15

Voltage Per Terminal Configuration

Terminals	Volt	Earth Terminal
AKZ 4	275V	AKE 4



TS 15 Mini Rail

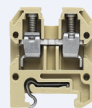

Mini Terminals for conductor sizes 0.5 to 4mm<sup>2</sup>



Insulated Terminal Connector 0.5mm to 16mm

FIGURE 1

The wiring insulation must not extend by more than 1.0mm from the metal face of the terminal as shown below.

