

CW INSULATED CAPTIVE COMPONENT GLAND®

for Steel Wire and Aluminium Armoured Cable



Features and Benefits

- For indoor and outdoor use.
- Gland is insulated from the equipment to prevent system circulating currents.
- Freely rotating captive cone and inspectible cone ring, providing an armour clamp and earth bond without twisting the armouring.
- Patented disconnect armour clamp system for ease of inspection.
- Provides a seal on the outer sheath of the cable, sealing to IP65/66.
- Precision manufactured from high-quality Brass (nickel-plated), available in Aluminium or Stainless Steel 316/316L on request.
- Supplied with a heavy-duty (nickel-plated) Locknut.



Technical Data

Type:	CW Insulated
Gland Material:	Brass (Nickel Plated) BS 2874, EN 12164, Aluminium ASTM B221, Stainless Steel 316/316L
Seal Material:	Thermoset Elastomer
Cable Type:	Steel Wire Armour, Aluminium Armour Wire
Armour Clamping:	Rotating Captive Cone and Inspectible Cone Ring
Sealing Area:	Outer Sheath
Optional Accessories:	Adaptor, Reducer, Earth Tag, Serrated Washer and Shroud

Standards and Certifications

Mechanical Properties:	Impact Category 8 Anchorage Type D	
Continuous Operating Temp:	-65°C to +120°C	
Conformance:	Standard:	Certificate:
Design Standards	BS 6121: Part 1 IEC/BS EN 62444 SANS 62444 SANS 1213	CML 14CA364 CML 14CA364 MASC 22-9012 MASC 26-9013, SANS 2109/4596
IP66 - Parallel	IEC 60529	MASC 22-9015
Marine ABS	IEC 62444	25-0167207-PDA
DNV	IEC 60529, BS 6121, IEC 62444	TAE000000Z
EMC Compatible	EN 55011, + A1, EN 55022	SGS EMC305079/1
London Underground Approval	BS EN 62444	LU 3044

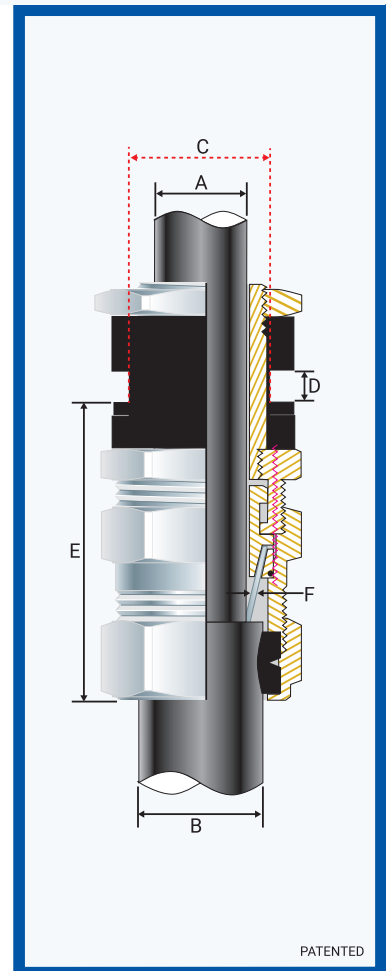

Installation Standards

- AS/NZS 3000
- BS 7430
- BS 6121-5
- IEC 60364-5-54
- BS 7671
- SANS 0142

Product Code	Gland Size Reference	Metric Entry Thread		Cable Detail			Max Length 'E'	Armour Dia		Hexagonal Detail		Install. Torque Value Nm
		'C'	Max 'D'	Max 'A'	Min 'B'	Max 'B'		Min 'F'	Max 'F'	Max 'Flats'	Max 'Crns'	
0532-0	0-20s	20	10	12.0	11.5	16.0	44.5	0.90	1.25	♦24.0	♦27.0	35.0
053201	1-20	20	10	15.0	14.5	20.5	50.0	0.90	1.25	27.0	30.0	35.0
053222	2s-25s	25	10	17.5	16.0	24.5	58.0	1.25	1.60	35.0	39.0	50.0
053202	2-25	25	10	20.0	20.5	26.5	53.0	1.25	1.60	35.0	39.0	50.0
053233	3s-32s	32	10	22.0	23.0	30.5	60.0	1.60	2.00	42.0	47.0	70.0
053203	3-32	32	10	26.5	26.5	33.5	68.0	1.60	2.00	42.0	47.0	70.0
053244	4s-40s	40	10	31.5	30.0	39.5	68.0	1.60	2.00	52.0	59.0	90.0
053204	4-40	40	10	34.0	33.0	42.5	68.0	1.60	2.00	52.0	59.0	90.0
053255	5s-50s	50	10	38.0	34.0	47.5	73.0	2.00	2.50	65.0	74.0	100.0
053205	5-50	50	10	44.5	42.5	52.5	84.0	2.00	2.50	65.0	73.0	100.0
053266	6s-63s	63	10	50.0	45.5	60.5	86.0	2.00	2.50	80.0	90.0	120.0
053206	6-63	63	10	56.5	52.5	65.5	86.0	2.00	2.50	80.0	90.0	120.0
053207	7-75	75	10	67.5	57.0	72.5	100.0	2.50	3.15	96.0	102.0	120.0
053277	7s-75s	75	10	62.0	57.0	73.0	114.0	2.50	3.15	96.0	102.0	120.0
053208	8-80	80	10	74.0	78.0	78.0	105.0	2.50	3.15	96.0	102.0	120.0
053209	9-90	90	10	81.5	82.0	91.0	136.0	3.00	3.50	111.0	126.0	120.0
053210	10-100	100	10	91.0	90.0	100.0	165.0	3.00	3.50	125.0	141.0	120.0
053211	11-110	108	10	98.0	100.0	114.0	180.0	3.00	4.00	135.0	152.0	120.0

All dimensions are in mm.

♦ When manufactured in Aluminium, Hex will be 27 Across Flats and 30 Across Corners.

CW INSULATED CAPTIVE COMPONENT GLAND®

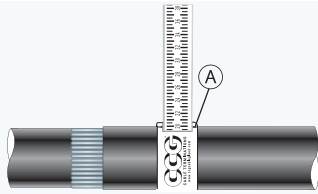

1. For accurate sizing, use a CCG Dimension Tape (A) on the inner and outer cable sheath.

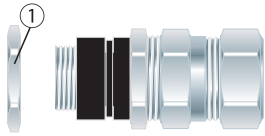

2. Remove the locknut (1).

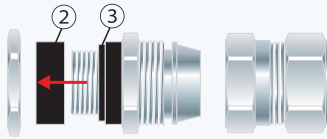

3. Remove female insulator ring (2). To maintain IP66, ensure the gasket (3) is in place.

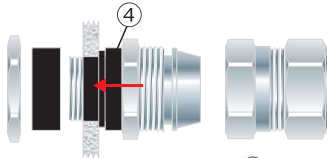

4. Insert the male insulator entry (4) into the cable entry of the apparatus.

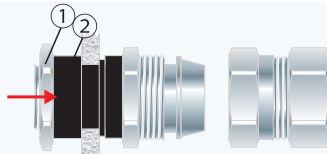

5. Screw the female insulator ring (2) back against the apparatus (maximum of 10mm thickness). Screw the locknut (1) back against the female insulator ring (2).

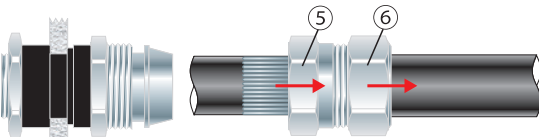

6. Pass the outer nut (6) and the body (5) over the cable and strip the cable outer sheath.

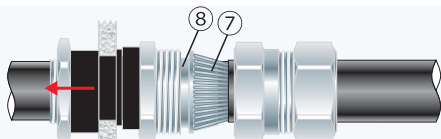

7. Pass cable end through the inner and splay the armour wires (7) over the cone (8).

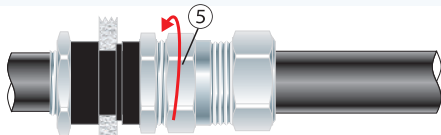

8. Tighten the body (5) onto the inner (2) until hand tight, then tighten with a CCG Spanner (10) with $\frac{3}{4}$ turn to lock the armour between the cone (8) and the cone ring (9).

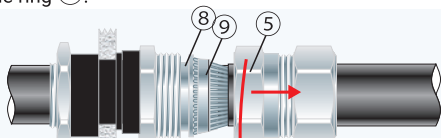

9. Unscrew the body (5). Check that the armour has locked between the cone (8) and cone ring (9). (O-Rings on the cone (8) and cone ring (9) are sacrificial).

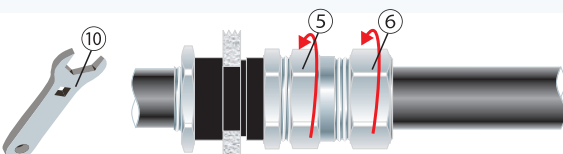

10. Tighten the body (5) onto the inner using a CCG Spanner (10). Tighten the outer nut (6) onto the body (5) to produce a moisture-proof seal by turning until seal makes contact with the outer sheath of the cable and then turn one full turn.